

# RESCUE BOAT RIBO 340 P SLING

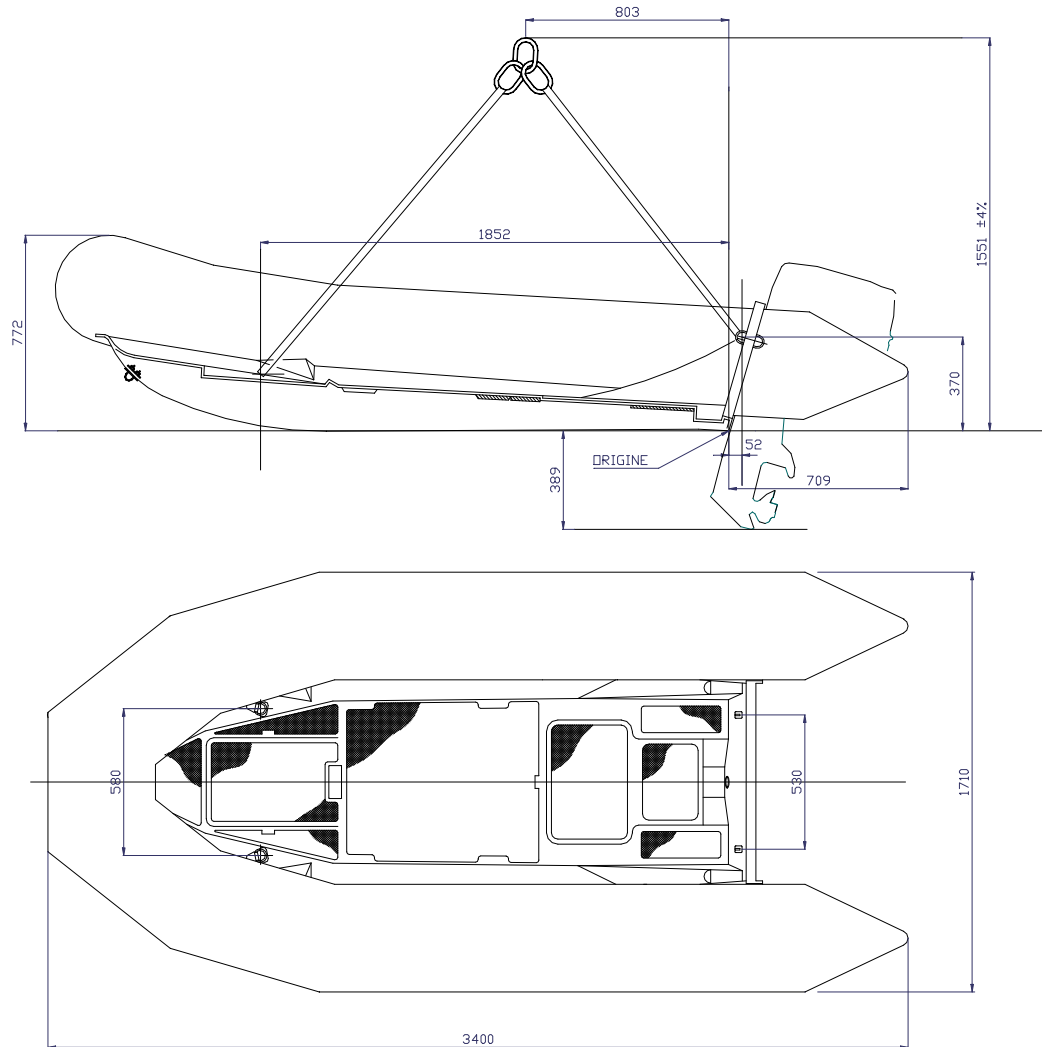

Overall dimensions with lifting sling

RIBO 340 Neo 28102015 KLT.doc	Issue: 6	Date: 28/10/2015
-------------------------------	----------	------------------

Dimensions and weight +/- 5%  
 SURVITEC SAS reserves the right to change specification without notice.  
 For installation, add minimum +10mm for clearance to dimensions of the container.

CAPACITY				
Number of persons: 5			Buoyancy volume: 1060 l / 32.5 cft	
DIMENSIONS				
Length		Width		Buoyancy diameter
Overall	Inside	Overall	Inside	0.450 m / 1'6"
3.40 m / 11'2"	2.30 m / 7'7"	1.71 m / 5'7"	0.80 m / 2'8"	
SAFETY / INFLATION				
. 5 airtight compartments		. 5 inflation valves		. 5 overpressure valves
WEIGHT				
With equipment & batteries		With equipment, engine (25 CV) & fuel		Operational weight with passengers (25 CV)
120 kg / 264 lbs		220 kg / 484 lbs		632 kg / 1393 lbs
ENGINE				
Shaft length		Engine power		Fuel tanks
long		25 CV 19 kw		2 x 25 l 2 x 6.6 l USCG
TOWING				
. 2 bow towing rings on hull . 2 towing points on transom		. 1 bow towing V with on load release shackle . 1 aft towing V with snap hook		
HOISTING				
. 2 bow lifting points		. 2 aft lifting points on transom		. 1 lifting sling
FABRIC				
. Neoprene fabric . Reflective tapes		. Buoyancy . Peripheral rubbing strake		
HULL				
. GRP composite rigid orange hull . 1 hull drain				

RIBO 340 Neo 28102015 KLT.doc

Issue: 6

Date: 28/10/2015

Dimensions and weight +/- 5%  
SURVITEC SAS reserves the right to change specification without notice.  
For installation, add minimum +10mm for clearance to dimensions of the container.

TRANSOM	
. 1 self bailer	. Engine aluminium mounting plate + wooden plate
HANDLING	
. 2 inside lifelines	. 2 outside lifelines . 2 paddles' supports
SEATING	
. 1 fixed bench	. 1 tiltable bench
EQUIPMENT FIXED TO THE RESCUE BOAT	
<ul style="list-style-type: none"> <li>. Towing line (50m)</li> <li>. Boat hook</li> <li>. Removable bow cover</li> </ul>	<ul style="list-style-type: none"> <li>. Righting lines (2)</li> <li>. Paddles (2)</li> <li>. Rescue quoits (2)</li> <li>. Flashing light</li> <li>. Boarding ladder</li> <li>. Radar reflector</li> </ul>
OTHER EQUIPMENT	
<ul style="list-style-type: none"> <li>. Compass</li> <li>. Sponge (2)</li> <li>. First aid kit</li> <li>. Search light</li> <li>. Thermal protective aid (2)</li> </ul>	<ul style="list-style-type: none"> <li>. Whistle</li> <li>. Sea anchor</li> <li>. Floating knife</li> <li>. Electrical torch</li> <li>. Bailer</li> <li>. Repair kit</li> <li>. Fire extinguisher</li> <li>. Torch spare bulb &amp; batteries</li> <li>. Pump</li> <li>. Manual</li> <li>. Equipment bag</li> </ul>
OPTIONS	
<ul style="list-style-type: none"> <li>. Release hook: SWL <math>\geq</math> 600 kg</li> <li>. <b>SOLAS Engine:</b> Tohatsu M25C3 L -</li> <li>. Propeller pitch: 3 x 9,8 x 8</li> </ul>	<ul style="list-style-type: none"> <li>. Overall cover</li> <li>Maximum towing force: 150 daN</li> <li>Engine weight: 51 kg</li> </ul>

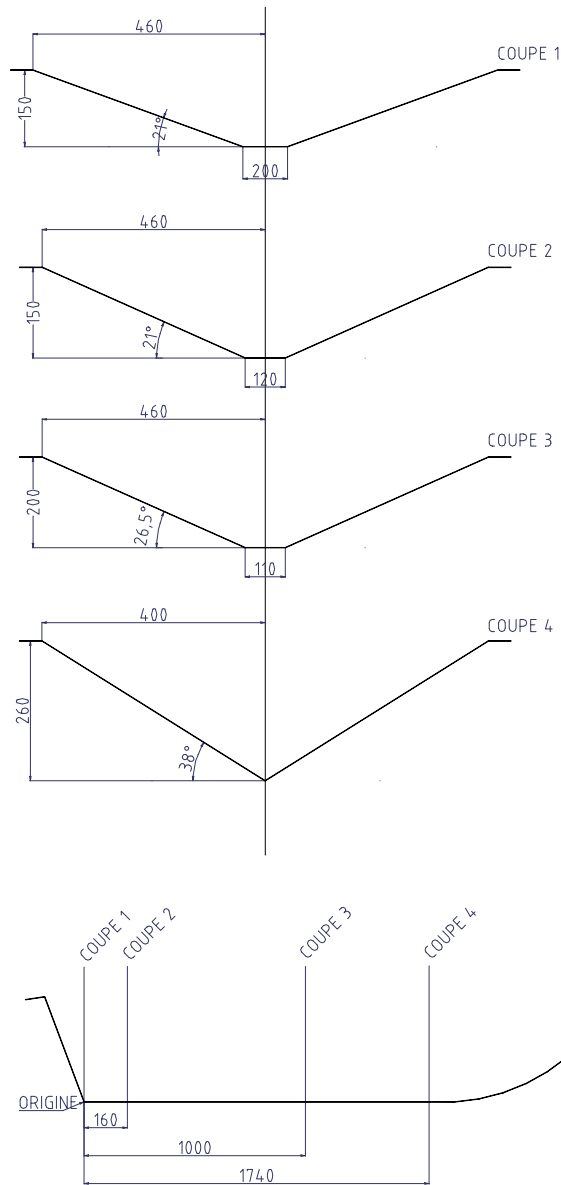

Hull profile

**Approvals:** BV – TC

RIBO 340 Neo 28102015 KLT.doc	Issue: 6	Date: 28/10/2015
-------------------------------	----------	------------------

Dimensions and weight +/- 5%  
 SURVITEC SAS reserves the right to change specification without notice.  
 For installation, add minimum +10mm for clearance to dimensions of the container.